



CK10SE Series

25 - 40 HP



CK10SE SERIES

Powerfully built. Powerfully comfortable.

The CK10SE Series - proof you can work hard around your land and still be surrounded by comfort and style. You and your land deserve it.

**Manual or HST
ROPS or CAB
Premium Features**

**Eco-Friendly Diesel Engine
Dual Rear Remote Valves
Single Lever Joystick**





KIOTI RC1060





Standard Wipers & Rear Defrost (Cab)

Cab models come equipped with standard front and rear window wipers. The wipers are positioned to minimize impact to the operator's field of vision. The rear window defrost maintains excellent rear visibility when operating in cold climates where frozen precipitation is common.



Independent PTO Switch

The standard rear Independent PTO is easily engaged by the simple turn of a knob. A safety interlock prevents the engine from starting if the PTO switch is left on. All models come standard with a selectable manual or automatic PTO option. When the Auto PTO is engaged, the PTO will automatically shut off when the 3-point control is raised, eliminating exposure to running implements.



Single Lever Joystick

Front end loader work is made easier by the use of a single lever joystick. The lever returns to neutral when released. A float position allows the bucket free flotation over the ground surface.

Panoramic Cab View

The large unobstructed windows provide a panoramic view for increased sight lines.

Rear 3-Point Control Lever (Cab)

Cab models come with a standard rear 3-point lever to easily raise and lower the lift arms from outside the tractor when attaching implements.



CK10SE STRENGTH AND COMFORT IN ONE MACHINE

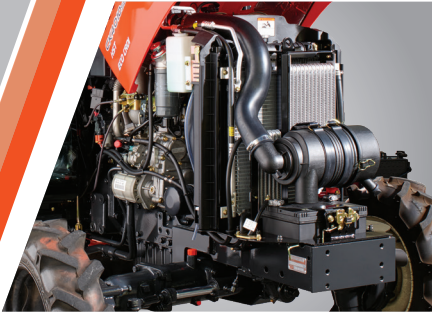

Dual Air Cleaner

Extending filter life, the dual air cleaner offers increased filtration when working in dry, dusty environments.



Illuminated Dashboard

The illuminated dashboard ensures great visibility while working in bright daylight or at night.



Power Steering with Tilt

The standard power steering minimizes the effort required to make tight, repetitive turns. The steering wheel tilts to adjust for operator needs.



Deluxe Suspension Seat

The ergonomically designed, adjustable suspension seat with dual armrests allows the operator to ride in comfort no matter what the task may be. The standard seat belt and operator presence switch ensure operator safety is prioritized.

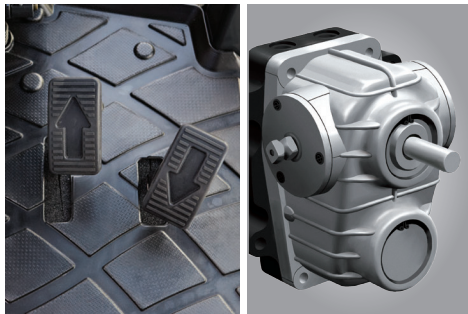

Manual and HST Models

The CK10SE Series delivers power and efficiency with all models featuring performance proven transmissions. Manual transmissions feature 12 Forward and 12 Reverse speeds with synchronized shuttle delivering heavy duty performance. The three range HST transmission (Hi/Mid/Low) with twin pedal operation makes your job easier, smoother and safer.



HST Linked Pedal

When the HST linked pedal is engaged, the HST pedal and the engine rpm are synchronized. As the forward or reverse pedal is depressed, engine RPM's increase to provide more torque for increased load. This reduces fuel consumption and simplifies tractor operation for a variety of utility and loader applications. Only available on HST models.



Telescopic Lower Links & Stabilizers

Standard telescopic lower link ends and stabilizers allow the operator to easily connect & adjust a wide variety of 3-point implements.

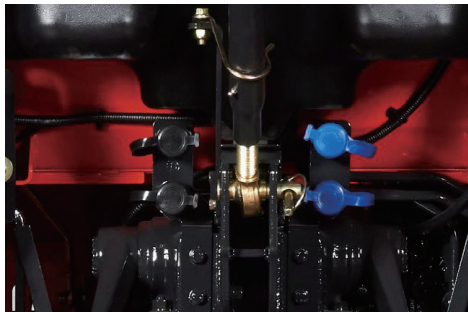

Dual Rear Remote Valves

The CK10SE Series comes standard with dual remote hydraulic valves to accommodate a wide variety of implements.



Eco-Friendly Diesel Engine

The diesel engine provides powerful performance and improves fuel efficiency while reducing noise levels. With this Tier 4 compliant engine, the CK10SE Series offers the operator a quiet work environment with powerful performance.



**KIOTI TRACTOR
PREMIUM CK10SE SERIES**



Front End Loader

The KIOTI KL4030 front end loader is specifically designed for the CK10SE Series tractor models, providing efficient performance with single lever joystick control and a dual lever quick attach bucket. The loader is designed to be quickly and easily attached and detached with the assistance of a built-in parking stand. KL Series loaders utilize the tractor's hydraulic system, feature single-lever control with float and come with a bucket level indicator.

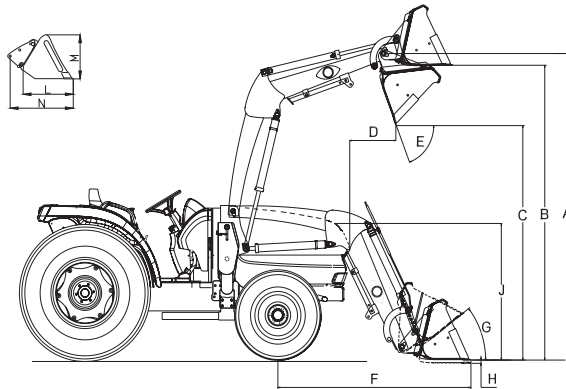

Loader Specifications

MODEL	KL4030
A Maximum Lift Height to Pivot Pin	98.4 in. (2,500 mm)
B Clearance w/ Bucket Level	93 in. (2,360 mm)
C Clearance w/ Bucket Dumped	79.1 in. (2,010 mm)
D Reach at Maximum Height (45°)	27.2 in. (690 mm)
E Maximum Dump Angle	48°
F Reach w/ Bucket on Ground	62.2 in. (1,580 mm)
G Maximum Rollback Angle	28°
H Digging Depth Below Grade	5.3 in. (135 mm)
J Overall Height in Carry Position	49.6 in. (1,260 mm)
L Bucket Depth (Inner Shell)	19.9 in. (505 mm)
M Bucket Height	20.7 in. (526 mm)
N Bucket Length (Pivot Pin)	26.9 in. (682 mm)
Lift Capacity at 59.84 in. (1,520 mm) Pivot Pin Height	1,835 lbs. (832 kg)
Breakout Force at Pivot Pins	3,464 lbs. (1,571 kg)
Relief Valve Setting (Loader Control Valve)	2,560 psi
Rated Flow (Tractor System)	6.9 gpm (26.12 L/min)
Bucket Size(s) Available (QA)	60 in. / 66 in.
Approximate Weight (With Bucket)	60 in.: 959 lbs. (435 kg) / 66 in.: 981 lbs. (445 kg)
Bucket Capacity (Heaped)	60 in.: 9.39 cu. ft. / 66 in.: 10.10 cu. ft.
Bucket Rollback Force at Ground Line	1,763.7 lbs. (800 kg)
Cycle Times	2,600 rpm (Full)
Raise Boom Frame	3.9 sec
Lower Boom Frame	2.3 sec
Dump Bucket	3.2 sec
Retract Bucket	1.9 sec

Backhoe

The KIOTI KB2475L backhoe lets you trench up to 89.7" deep with a bucket dig force up to 2,817 pounds. The KB2475L backhoe features subframe mounting, responsive two-lever controls with exceptional feathering, hydraulic stabilizers, transport lock and a variety of standard and heavy-duty buckets.

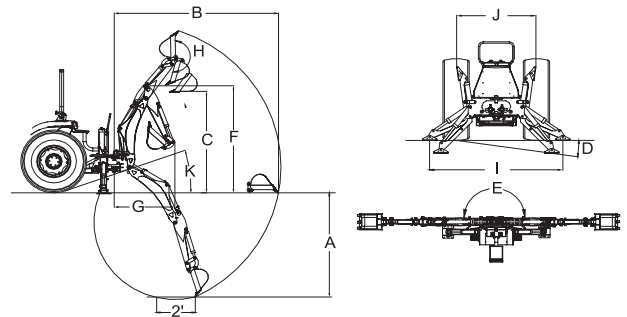

Backhoe Specifications

MODEL	KB2475L			
A Digging Depth (Two Foot Flat Bottom)	89.7 in. (2,280 mm)			
B Reach from Center Line of Swing Pivot	125.1 in. (3,180 mm)			
C Loading Height (Bucket at 60°)	72.4 in. (1,840 mm)			
D Maximum Leveling Angle	10°			
E Swing Arc	180°			
F Transport Height (Maximum)	83.5 in. (2,120 mm)			
G Transport Overhang	49 in. (1,245 mm)			
H Bucket Rotation	180°			
I Stabilizer Spread (Down Position)	68.7 in. (2,120 mm)			
J Stabilizer Spread (Up Position)	46.4 in. (1,180 mm)			
K Angle of Departure	21°			
Shipping Weight (Without Bucket)	880 lbs. (399 kg)			
Bucket Digging Force	2,817.5 lbs. (1,278 kg)			
Dipperstick Digging Force	2,105 lbs. (955 kg)			
Operating Pressure	2,466 psi (170 bar)			
Cylinders				
Cylinder	Bore DIA	Retracted Length	Stroke	Rod DIA
Boom	2.36	20.66	12.36	1.37
Bucket	2.36	18.70	9.64	1.37
Dipperstick	2.36	19.68	11.20	1.37
Swing	2.36	15.23	7.87	1.37
Stabilizer	1.96	18.30	10.43	1.18
Bucket Sizes				
Bucket	Teeth Quantity	Struck Capacity	Heaped Capacity	Shipping Weight
9" Bucket	3	0.73 cu. ft.	0.87 cu. ft.	46 lbs.
12" Bucket	3	1.01 cu. ft.	1.24 cu. ft.	56 lbs.
16" Bucket	3	1.38 cu. ft.	1.76 cu. ft.	64 lbs.
18" Bucket	4	1.56 cu. ft.	2.02 cu. ft.	70 lbs.
24" Bucket	5	2.11 cu. ft.	2.82 cu. ft.	94 lbs.
36" Bucket	6	2.78 cu. ft.	4.00 cu. ft.	114 lbs.

* Specifications and design are subject to change without notice.

* Specifications and design are subject to change without notice.



ISO 9001
NO.954596



ISO 14001
NO.771475



OHSAS 18001
NO.K033008

SPECIFICATIONS

MODEL	CK2610SE HST Cab	CK3510SE	CK3510SE HST	CK3510SE HST Cab	CK4010SE	CK4010SE HST	CK4010SE HST Cab
ENGINE							
Model	3A165LWH-U	3H-TM4B	3H-TH4B	3H-TH4B	3H-TM4B	3H-TH4B	3H-TH4B
Type	3 Cyl., In-line Vertical, Water-cooled 4-cycle Diesel, CRDI						
Engine Gross hp (kW)	24.5 (18.3)	34.9 (26)	34.9 (26)	34.9 (26)	39.6 (29.5)	39.6 (29.5)	39.6 (29.5)
PTO @ Rated PTO rpm	18.6 (13.8)	30.9 (23)	28.9 (21.5)	28.9 (21.5)	34.8 (26)	33.3 (24.8)	33.3 (24.8)
Displacement cu. in. (cc)	100.5 (1,647)	111.4 (1,826)					
Rated Revolution rpm	2,400	2,600					
Fuel Tank Capacity US gal. (ℓ)	9.0 (34)						
DRIVE TRAIN							
Clutch	N/A	Dry Single	N/A	Dry Single	N/A	N/A	
Transmission	HST	Synchro Shuttle	HST	Synchro Shuttle	HST	HST	
Speeds	3 range	12×12	3 range	12×12	3 range	3 range	
Differential Lock	Rear Standard						
Brake	Wet Disc Type						
PTO Type	Independent						
Rear PTO (Standard) rpm	540						
Mid PTO (Optional) rpm	(2,000)						
4WD Type	Mechanical Actuated						
HYDRAULIC SYSTEM							
Pump	Gear						
Pump Capacity (Max. Flow Rate) gpm (L/min)	11.3 (42.9)						
3-Point Hitch	Category I						
Maximum Lifting Capacity (24" aft. of hitch) lb. (kg)	1,631 (740)						
Hydraulic Lift Control System	Position						
Number of Remote Valves	Standard (4 Port)						
Steering	Hydrostatic Power Steering						
TIRE SIZE							
Front AG. (Turf, Industrial)	7-16 (25×8.5-15, 27×8.5-15)						
Rear AG. (Turf, Industrial)	11.2-24 (41×14-20, 15-19.5)						
TRAVELING SPEEDS							
Forward mph (km/h)	0~17.45 (0~28.1)	1.0~15.0 (1.7~24.2)	0~15.4 (0~24.7)	1.0~15.0 (1.7~24.2)	0~15.4 (0~24.7)	0~15.4 (0~24.7)	
Reverse mph (km/h)	0~12.22 (0~19.7)	1.0~9.21 (1.6~23.6)	0~9.2 (0~14.8)	1.0~9.21 (1.6~23.6)	0~9.2 (0~14.8)	0~9.2 (0~14.8)	
DIMENSIONS							
Overall Length (Includes 3-pt Hitch) in. (mm)	120.9 (3,070)						
Overall Width (Minimum Tread) in. (mm)	54.5 (1,385)						
Overall Height in. (mm)	92.5 (2,350)	99.2 (2,520)	91.7 (2,330)	99.2 (2,520)	91.7 (2,330)	91.7 (2,330)	
Wheelbase in. (mm)	65.7 (1,670)						
Min. Ground Clearance in. (mm)	13.4 (340)						
Tread	Front (AG.) in. (mm)	48.2 (1,225)					
	Rear (AG.) in. (mm)	47.6 (1,210)					
Min. Turning Radius (with brake) ft. (m)	8 (2.5)						
Weight with AG. Tires lb. (kg)	3,397 (1,541)	2,906 (1,318)	2,921 (1,325)	3,397 (1,541)	2,906 (1,318)	2,921 (1,325)	3,397 (1,541)

* NOTE : Specifications and design are subject to change without notice.

STANDARD EQUIPMENT

- Headlights
- Signal Lamp
- Hand Cranked Leveling Box
- Illuminated Dashboard
- Horn
- Tilt Steering
- Hydrostatic Power Steering
- Cup Holder
- Dual Armrest
- Single Lever Joystick
- Toolbox
- Parking Brake
- Wet Multi Disc Brakes
- Floor Mat
- Dual Air Cleaner Element
- Rear PTO
- Flip Up PTO Cover
- Telescopic Lower Link
- Telescopic Stabilizers
- Dual Rear Remote Valves (Spring/Detent)
- Side View Mirror (2) (ROPS)
- Front Work Light (Cab)
- Rear Work Light (Cab)
- Front Window Wiper (Cab)
- Rear Window Wiper (Cab)
- Rear Window Defrost (Cab)
- A/C / Heater (Cab)
- Sunvisor (Cab)
- External 3-Point Control Lever (Cab)
- Cruise Control (HST)
- Link Pedal (HST)

OPTIONAL EQUIPMENT

- Mid PTO
- 3rd Function Valve
- Beacon Lamp Wire Kit
- Detent Holder Kit
- Clevis Type Drawbar
- Fuel Heater (35 and 40 hp Models Only)
- Block Heater
- Front Weights
- Rear Weights (Ag Tires Only)
- CD Player (Cab)
- Rear View Mirror (Cab)
- Sunshade (ROPS)
- Rear Working Light (ROPS)
- Lift Rod Kit

ATTACHMENTS

- Front End Loader
- Backhoe
- Snowblower
- Contact your local KIOTI dealer for available implements and attachments.



KIOTI Tractor Division
DAEDONG - USA, INC.
6300 KIOTI Drive, Wendell, NC 27591 USA
Toll free 877-GO-KIOTI • Fax 919-374-5001
Web www.KIOTI.com

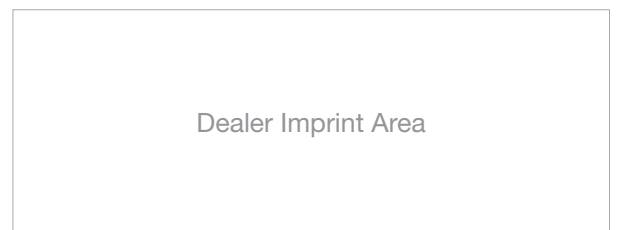

LIT-CK10SE-ALL3